

## Main Menu



TechNotes is a database designed to store, manage, and retrieve data, information, and photos of alarms, autos, electronics, locks, keys, motorcycles, safes, tools, etc.

### About the Demo:

The TechNotes demo will expire in 30 days and is limited to 5 entries per category.

After expiration, the demo can be activated to full program status and any data you entered will be available to you.

### System Requirements:

Windows XP Pro (SP2) / Vista / Windows 7 Professional

TechNotes is password protected by an account name and a password.

For distribution purposes, the default account name is administrator (**not case-sensitive**) and the default password is Admin (**case-sensitive – Cap A**).

The account name is not changeable.

The password is user changeable and should be changed to a secure password as soon as possible (see below).

## Changing the Password



To change the password, click “Reset Password” on the main menu.

In the following dialogue box:

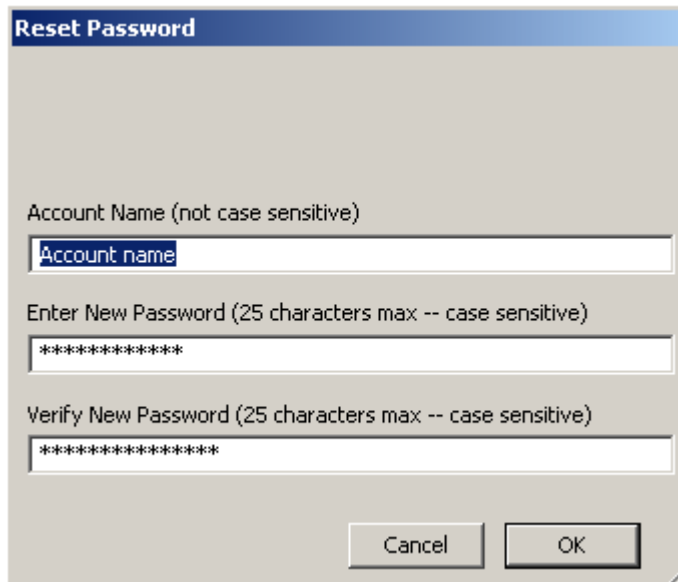
A dialog box titled "Reset Password" with a blue header bar. It contains three text input fields. The first field is labeled "Account Name (not case sensitive)" and contains the text "Account name". The second field is labeled "Enter New Password (25 characters max -- case sensitive)" and contains ten asterisks. The third field is labeled "Verify New Password (25 characters max -- case sensitive)" and also contains ten asterisks. At the bottom right, there are two buttons: "Cancel" and "OK".

Enter the account name (administrator). Then enter the new password (which will be case-sensitive). Then re-enter the new password. Click OK.

The next time you launch TechNotes, you will need the new password.

**IMPORTANT:** The password is secure. If you forget the password, there is no way to retrieve it, so make it something you can remember easily.

## About the Main Menu Buttons

### Exporting and importing backup records:



It's a good idea to periodically export the records in TechNotes to a backup file. If you have a drive failure or the database is damaged by a power surge, you could lose all your data, unless you have backup records.

If disaster strikes, you can re-install TechNotes from the original CD and import your records.

Click the button "Export Backup Records". This will export your records to the root folder of TechNotes (C:/Program Files/TechNotes).

Each category (safes, alarms, autos, etc) will be exported separately to its own file – safes.bak, alarms.bak, etc).

If you need to re-install TechNotes, just click the button "Import Backup Records".

Your backup files MUST be in the root folder. TechNotes will look for them there and import each one into the proper category.

### Category buttons:

To enter data in a particular category, click the appropriate button.





## Safe Records:

### Detail Screen:

The screenshot displays the 'Safes' application interface. At the top, a blue navigation bar contains the 'Safes' logo, navigation arrows, and buttons for 'Index', 'New Entry', 'Find', 'Delete', 'Summary', 'Print', and 'Find All'. Below this, the 'Manufacturer' field is set to 'Schwab', the 'Style' field is set to 'Floor', and the 'Model' field is empty. The date '3/31/2006' is shown in the top right, and an 'Add Notes' button is present. The main area features four photo slots, each with 'Add / Replace Picture' and 'Delete Picture' buttons above it and a 'Click here to enlarge' link below it. The top-left slot shows a close-up of a brass internal mechanism. The top-right slot shows another view of the same mechanism. The bottom-left slot shows a full view of a green metal safe. The bottom-right slot is currently empty. A 'Close Window' button is located at the bottom center of the interface.

Records the manufacturer, style, and model of safes.

You can place up to four photos for any entry.

## Buttons:



For moving through records. Clockwise from upper left: previous record, next record, last record, first record.



Returns you to the index screen.



Provides a summary of records in each category:



Creates a new record in the current category.

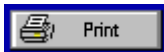

Prints the current record. Any notes for the record are included in the printout.



Finds a record in the current category:



Finds all records in the current category.



Deletes the current record.

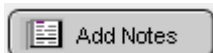

Enter notes pertaining to the current record:

**Placing photos:**

You can place up to four photos for each record.

To place or replace a photo, click the “Add/Replace Picture” button.

To delete a photo, click “Delete Picture”.

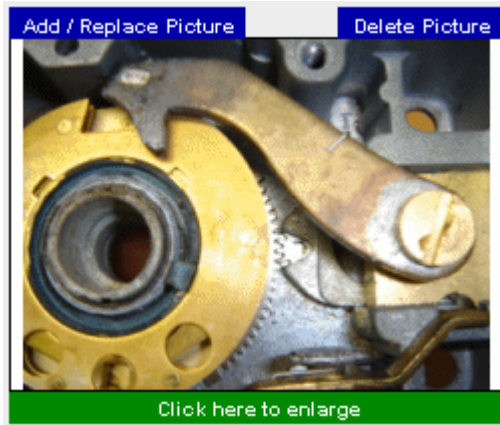

Photos should be .gif or .jpg format.

If .jpg, they should be in RGB format rather than CMYK.

Digital cameras usually are RGB formatted .jpg.

To view a large version of the photo, click "Click here to enlarge":

**Safes** Return Print

Manufacturer: **Schwab**      Style: **Floor**      Model:



Close Window

The image shows a close-up of a mechanical assembly, likely a safe dial or handle mechanism. A prominent yellow gear is visible on the left, with a metal handle or lever extending from it. The handle has a circular end with a slot. The background shows various metal components, including a gear and a handle, all appearing to be part of a complex mechanical system. The interface is framed by a blue border with a white header and footer. The header contains the 'Safes' logo, a 'Return' button, and a 'Print' button. The footer contains a 'Close Window' button. The main content area has a light gray background with three input fields for 'Manufacturer', 'Style', and 'Model'. The 'Manufacturer' field is filled with 'Schwab', the 'Style' field is filled with 'Floor', and the 'Model' field is empty.

Click "Return" to go back to the detail screen.



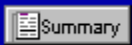





To print the enlarged photo, click "Print" in the upper right corner.



Provides a summary of all records in a particular category:

**Safes** Return Print

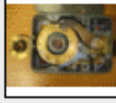
Sort by Manufacturer Sort by Style Sort by Model

Manufacturer	Style	Model	3/31/2006		
<input type="checkbox"/> Mosler	Floor				
<b>Notes</b> Enter notes here.					
<input type="checkbox"/> Diplomat	Stand Up				
<b>Notes</b> Enter notes here.					
<input type="checkbox"/> Mosler	Miscellaneous				
<b>Notes</b> Enter notes here.					
<input type="checkbox"/> Schwab	Floor				
<b>Notes</b> Enter notes here.					

Close Window

To go to any particular record, click the arrow next to the manufacturer of the record you want.  
Click "Return" to return to the details screen where you left off.  
Click "Print" to print the summary.

 Add Notes

Takes you to a screen where you can enter notes pertaining to the current record:

Manufacturer <b>Mosler</b>	Style <b>Floor</b>	Model
-------------------------------	-----------------------	-------

**Enter notes here.**

 Close Window

This field will hold 2 MB of text so you can be as detailed as you want.

You can enter up to six 8.5" x 11" pages worth of notes.

Notes are included in the printout when you print the record from the details page.

### Finding a record:



Click "Find" to find a record in the current category:

*Safes*

Manufacturer	Style	Model
<input type="text"/>	<input type="text"/>	<input type="text"/>

Perform Find

Cancel

Enter the search criteria and click "Perform Find". To cancel the find, click "Cancel".



Finds all records in the current category.

## Additional Categories:

[Alarm Index](#)

**Alarms**    < >    < Index >    < Summary >    < New Entry >    < Find >    < Delete >

< >    < Find All >    < Print >

Manufacturer: **Alarm Lock**    Component: **Exit**    Description: **schematics**    4/6/2006    < Add Notes >

[Add / Replace Picture](#)    [Delete Picture](#)



[Click here to enlarge](#)

[Add / Replace Picture](#)    [Delete Picture](#)

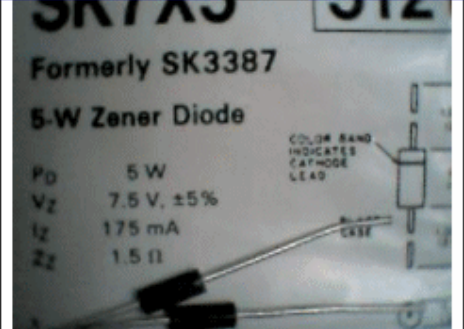

[Click here to enlarge](#)

[Add / Replace Picture](#)    [Delete Picture](#)

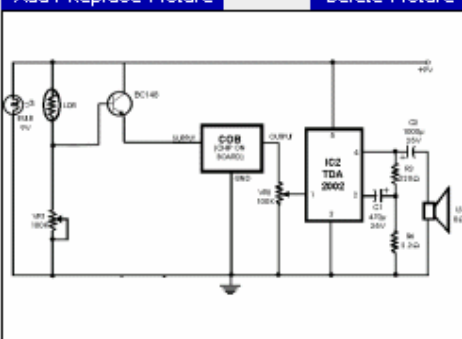

[Click here to enlarge](#)

[Add / Replace Picture](#)    [Delete Picture](#)

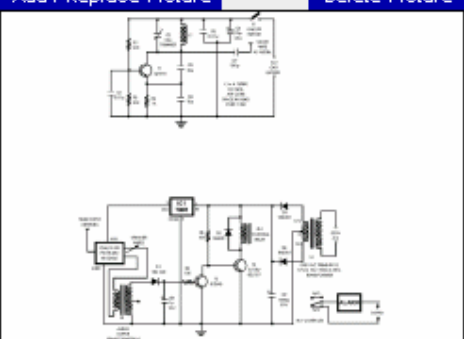

[Click here to enlarge](#)

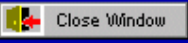
 Close Window

**Auto Index**

**Autos**
◀ ▶
◀ ▶
◀ Index ▶
🔍 New Entry
🔍 Find
🗑 Delete

⏪ ⏩
📄 Summary
🖨 Print
🔍 Find All

4/4/2006

Manufacturer: **BMW**      Year: **2001**      Model: **M5**      Category: **Mid size**
📄 Add Notes

Add / Replace Picture
Delete Picture



Click here to enlarge

Add / Replace Picture
Delete Picture

Depth & Spaces

Depth 1	Depth 2	Depth 3	Depth 4	Depth 5	Depth 6	Depth 7	Depth 8	Depth 9	Depth 10
340	315	250	255						
Space 1	Space 2	Space 3	Space 4	Space 5	Space 6	Space 7	Space 8	Space 9	Space 10
296	369	481	573	655	757	849			

Click here to enlarge

Add / Replace Picture
Delete Picture

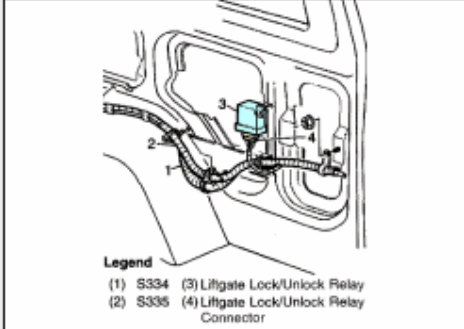

Click here to enlarge

Add / Replace Picture
Delete Picture

Click here to enlarge

**Electronic Index**

**Electronics**

3/31/2006

Manufacturer: **Ademco**      Component: **Panel**      Description:

Add / Replace Picture
Delete Picture



[Click here to enlarge](#)

Add / Replace Picture
Delete Picture

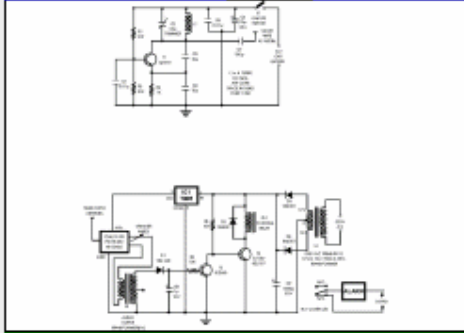

[Click here to enlarge](#)

Add / Replace Picture
Delete Picture

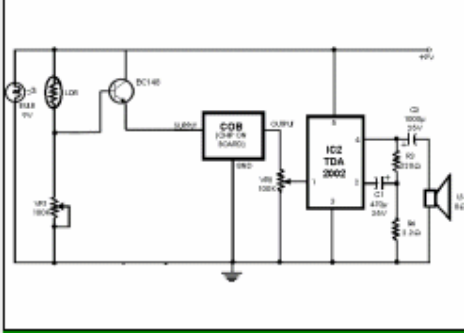

[Click here to enlarge](#)

Add / Replace Picture
Delete Picture

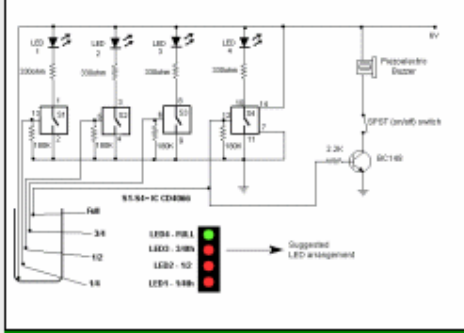

[Click here to enlarge](#)

Lock Index

**Locks**    < >    < Index >    < New Entry >    < Find >    < Delete >  
[ < > ]    < Summary >    < Print >    < Find All >

4/7/2006  
Manufacturer: **Arrow**    Function: **Various**    Keyway:    Code Series:    < Add Notes >

[Add / Replace Picture](#)    [Delete Picture](#)



[Click here to enlarge](#)

[Add / Replace Picture](#)    [Delete Picture](#)



[Click here to enlarge](#)

[Add / Replace Picture](#)    [Delete Picture](#)



[Click here to enlarge](#)

[Add / Replace Picture](#)    [Delete Picture](#)



[Click here to enlarge](#)

 Close Window

Key Index

Keys [Navigation] Index New Entry Find Delete Summary Print Find All

Manufacturer: Various Function: Keyway: Code Series: 12/15/2010 Add Notes

Add / Replace Picture Delete Picture



Click here to enlarge

Add / Replace Picture Delete Picture



Click here to enlarge

Add / Replace Picture Delete Picture



Click here to enlarge

Add / Replace Picture Delete Picture





Click here to enlarge

Close Window

**Motorcycle Index**

**Motorcycles**    < >    < Index >    New Entry    Find    **Delete**  
[ < > ]    Summary    Print    Find All

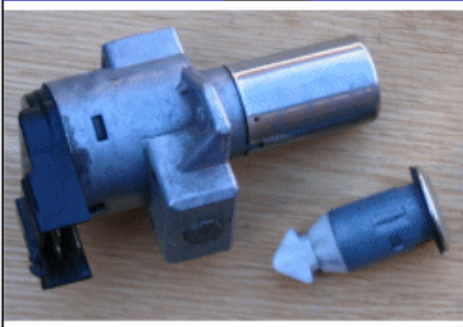
Manufacturer: **Yamaha**    Year: **2004**    Model: **Rhino**    Category:    4/4/2006  
Add Notes

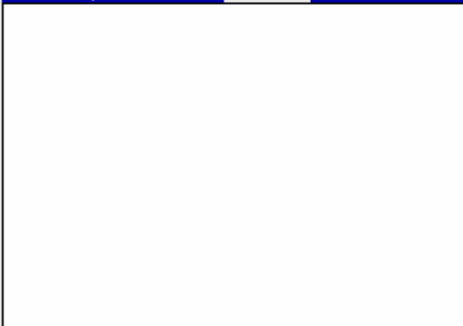
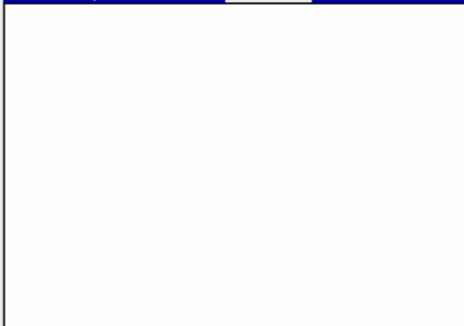
<p>Add / Replace Picture    Delete Picture</p>  <p>Click here to enlarge</p>	<p>Add / Replace Picture    Delete Picture</p>  <p>Click here to enlarge</p>
<p>Add / Replace Picture    Delete Picture</p>  <p>Click here to enlarge</p>	<p>Add / Replace Picture    Delete Picture</p>  <p>Click here to enlarge</p>

Close Window

Tools Index

**Tools** [Navigation icons] [Index] [New Entry] [Find] [Delete] [Summary] [Print] [Find All]

5/30/2006  
Manufacturer: **Intro Vision** Description: **Scope** Category: Function: [Add Notes]

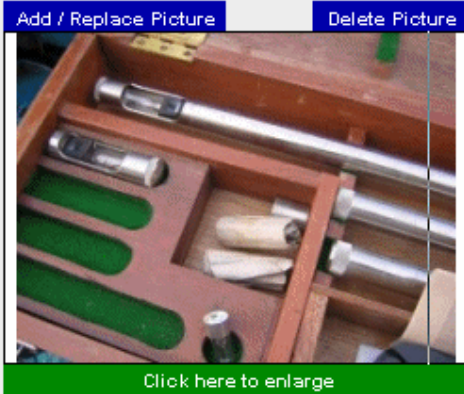
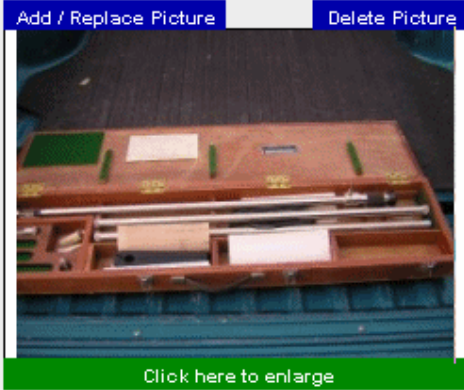

[Close Window]

Miscellaneous Index

**Miscellaneous**    [Left Arrow] [Right Arrow]    [Left Arrow] Index [Right Arrow]    [Lightbulb] New Entry    [Magnifying Glass] Find    [Trash] Delete

[Left Arrow] [Right Arrow]    [Document] Summary    [Printer] Print    [Magnifying Glass] Find All

Manufacturer: **Ives**    Description: **Flush bolt**    Category:    Function:    4/8/2006

[Document] Add Notes

<p>Add / Replace Picture    Delete Picture</p>  <p>Click here to enlarge</p>	<p>Add / Replace Picture    Delete Picture</p>  <p>Click here to enlarge</p>
<p>Add / Replace Picture    Delete Picture</p>  <p>Click here to enlarge</p>	<p>Add / Replace Picture    Delete Picture</p>  <p>Click here to enlarge</p>

[Close Window]